



Procurement Office
495 Upper Falls Blvd.
Rochester, NY 14605
Fax: 585-697-7164
WWW.ROCHESTERHOUSING.ORG

March 16, 2023

ADDENDUM #1

To: Potential Bidders

RE: Rochester Housing Authority

P9, P10, P11, P12 Porch Replacements
7 pages including this cover page

There are slight changes to each porch.
Porch addresses are on the next 6 pages.

Acknowledgement:

I have received the above referenced Addendum #1 and have used it in the calculation/preparation of this bid.

Contractor

Without acknowledgement of this addendum your bid may be non-responsive.

APD ENGINEERING | ARCHITECTURE

Rochester Housing Authority – Porch Renovations – P9, P10, P11, P12

This Addendum includes **Owner Changes**.

The changes are identified as follows in the sheet block:

- Issued for Construction (03/25/23)

Note:

54 Lincoln Street

- **A-101**

- Squared off sidewalk at bottom of ramp

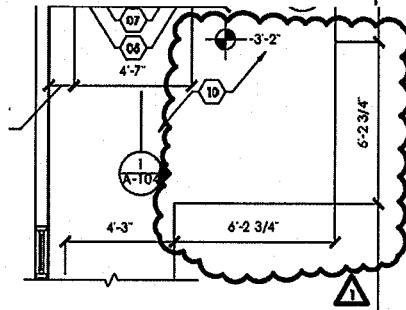

- Added below beam bearing posts

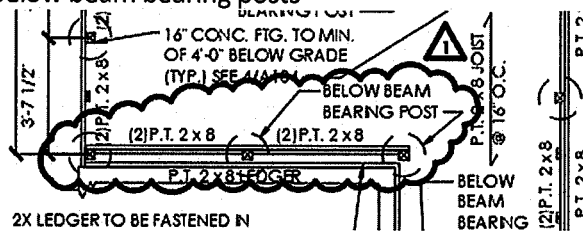

- **A-102**

- Added note for aluminum railing

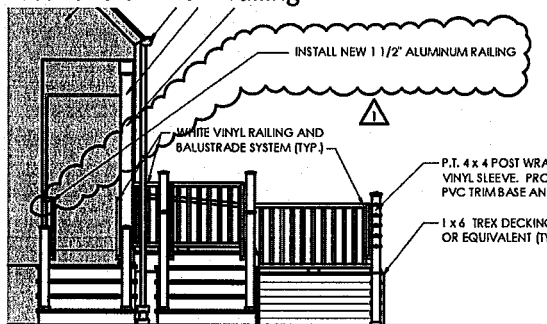

134 York Street

- **A-101**

- Clarified note for railing.

Headquarters

615 Fishers Run, Victor, NY 14564
 phone 585.742.2222 • fax 585.924.4914
 web www.apd.com • email info@apd.com

Office Locations

P.O. Box 11626, Santa Ana, CA 92711 • phone/fax 714.987.1380

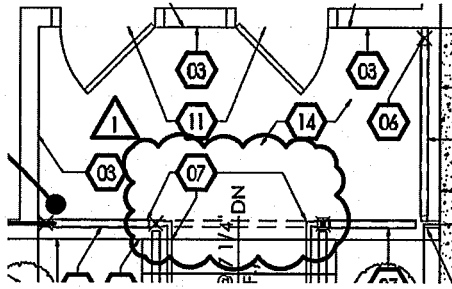

- A-102

- Added note for aluminum railing

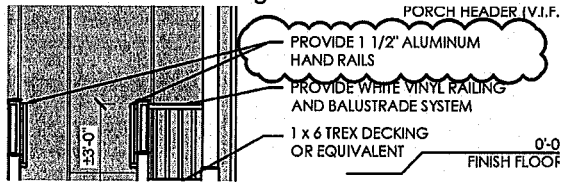

1 Bradford Street

- A-101

- Updated sidewalk replacement

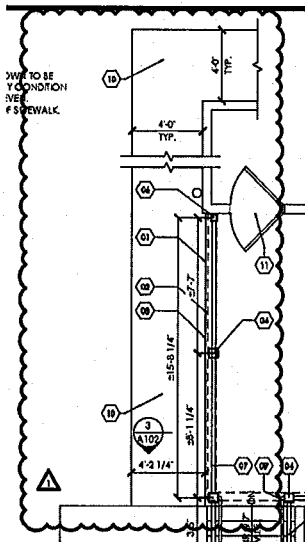

- Updated extent of driveway removal

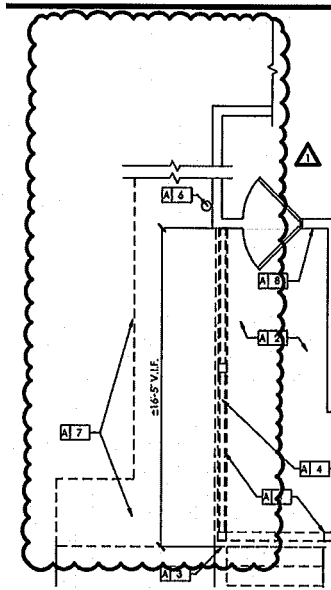

- Added fencing to front yard

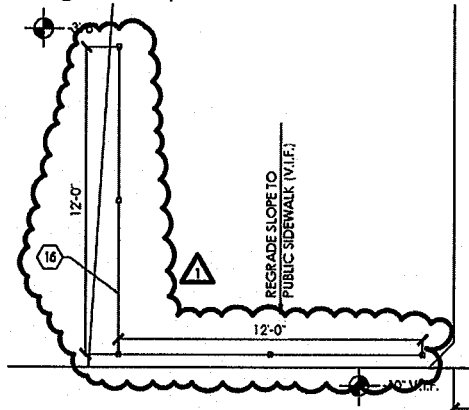

- A-102

- Added note for aluminum railing

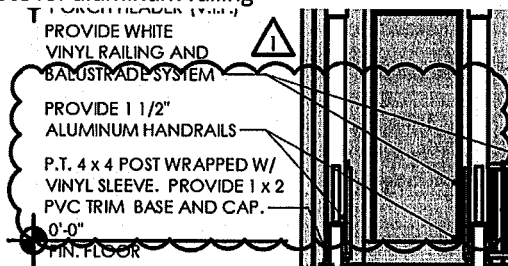

18 Council Street

- A-102

- Added note for aluminum railing

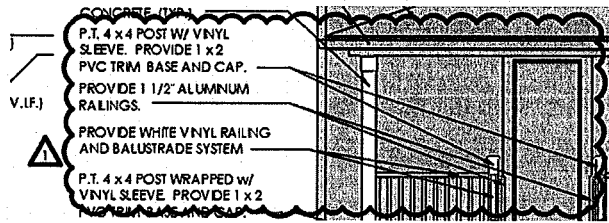

41A & 41B Ferncliffe Dr.

- A-102
 - Added note for aluminum railing

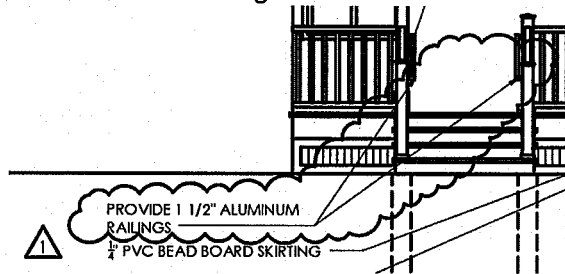

111 Rugby Ave.

- A-102
 - Added note for aluminum railing

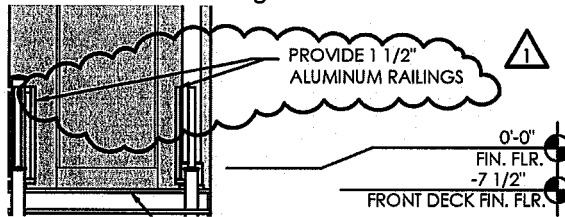

11 Coleman Terrace

- A-101
 - Added note for PVC trim at railings at house.

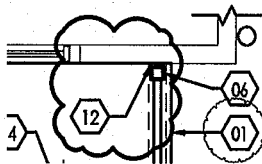

- A-102
 - Added note for aluminum railing

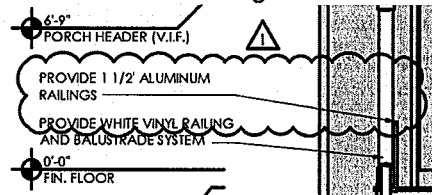

20-24 Waverly Place

- A-101

- Added note for removal of existing wall lighting

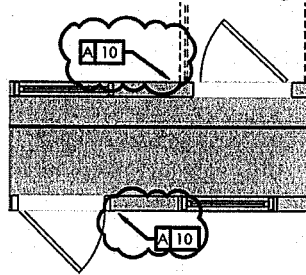

- Added note for railing

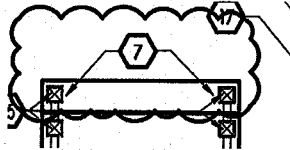

- Added note for new wall mounted lighting

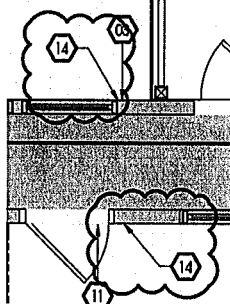

- Added note for patch, repair, replace ceiling as needed

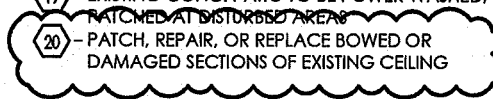

- A-102

- Added note for aluminum railing

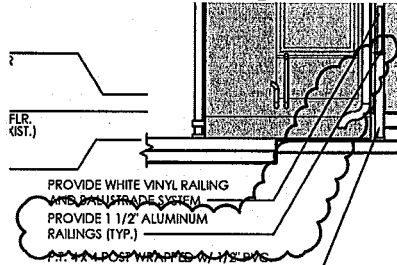

182-186 Troup Street

- A-101

- Added note for removal of existing wall lighting

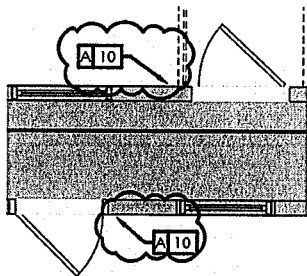

-
- Added note for railing

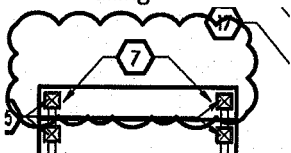

-
- Added note for new wall mounted lighting

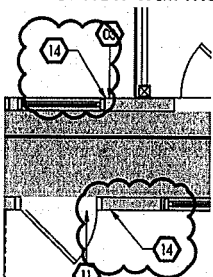

-
- Added note for patch, repair, replace ceiling as needed

PATCHED AT DISTURBED AREAS
 20 - PATCH, REPAIR, OR REPLACE BOWED OR
 DAMAGED SECTIONS OF EXISTING CEILING

- A-102

- Added note for aluminum railing

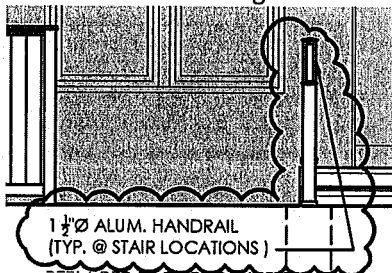

End of CCD-1